

LED Driver : Constant Voltage
 Operating Temperature : -10 ~ +50 [°C]
 Dimension : 58 x 28 x 22 [mm]
 Approvals / Marks : 



Features:

Constant voltage mode power supply - Suitable for LED lighting and moving sign applications
 Universal AC input / Fully encapsulated with IP67 (for indoor and outdoor use) Full range
 Fully encapsulated with IP67 level
 Protections: Over current / Over Voltage / 100% full load burn-in test

Specification:

	Model	Voltage DC [V]	min. Load [A]	max. Load [A]	Output Tol. [%]	Efficiency [%]	OVP [V]	Max. Power [W]	Ripple & Noise [mV] p-p
	HPCV-0512	12	0	0.4	±3	72	13~20	5	200
	HPCV-0524	24	0	0.2	±3	72	--	5	200
INPUT	Voltage	(100 ~ 240)VAC							
	Frequency	(47 ~ 63)Hz							
	Current	0.15A/220VAC 0.10A/100VAC							
	Inrush Current max.	30A/220VAC @ cold start							
	Leakage current	0.5mA/240VAC							
PROTECTION	Over current	Above 110% ~ 180% rated output power or short circuit. Protection type: Hiccup mode, recovers automatically.							
	Over Voltage	Protection type: Hiccup mode, recovers automatically.							
	Protection class	UL1310 Class 2 power unit							
	Over temperature	-							
	No Load Operation	-							
OTHERS	Isolation Resistance	I/P-O/P:>100MΩ / 500VDC / 25~70% RH							
	Set up time	500ms							
	Hold-up Time	50ms/240VAC at full load							
	MTBF Qualification	50K hours @ full load and 25°C							
	AC cable / DC cable	18AWG 250mm Striped&Tinned 18AWG 250mm Striped&Tinned							
	Rise time	250ms							
	Line regulation	±1.0%							
	Burn in	100% full load burn-in test							
	Load regulation	±2.0%							
ENVIRONMENT	Temperature	Operating: (-10 ~ +50)°C / Storage: (-40 ~ 80)°C							
	Humidity	Operating: (20 ~ +90)%RH / Storage: (10 ~ 95)%RH Non-condensing							
	Vibration	10 ~ 500Hz, 2G 10min./1cycle, period for 60min. each along X,Y, Z axes							
	Temp. Coefficient	±0.03%/°C (0~50°C)							
CERTIFICATION & SAFETY		Safety EN61347-1, EN61347-2-13 Immunity EN61547 Harmonic EN61000-3-2 Magnetic Emission EN55015 RoHS compliant CE mark / compliant UL standard design Pass LPS UL 1310 Class II power unit							
SAFETY & EMC	Withstand voltage	I/P-O/P:3KVAC							
	Safety standards	Design refer to UL1310 Class 2,TUV EN60950-1, EN61347-2-13, CAN/CSA C22.2 No. 223-M91, meet IP67							
	EMS Immunity	Compliance to EN61000-4-2,3,4,5,6,8,11; ENV50204, EN55024, light industry level, criteria A							
	EMI conduction & radiation	Compliance to EN55022 (CISPR22) Class B							
	Harmonic current	EN61000-3-2,-3							
WEIGHT		HPCV-0512							
	1pc	N.W.: 43g G.W.: 47g							
PACKING		0.345 x 0.235 x 0.28 [m]							
	Box	300pcs / 1box							
		G.W.: 14.5 kg / box							

Mechanical case and cable specification:

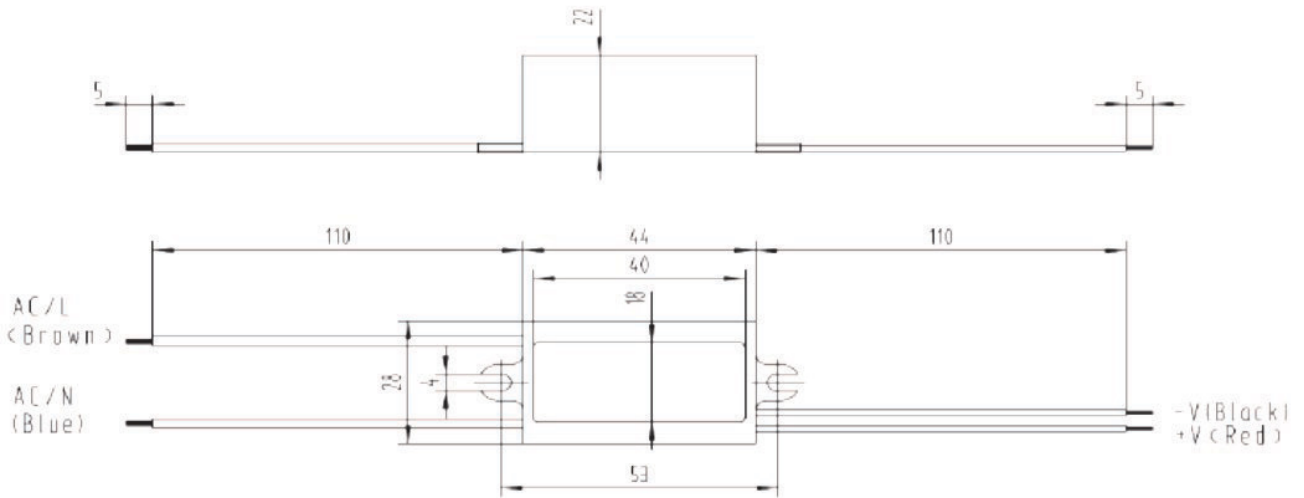

Block diagram:

