

LED Driver : Constant Voltage
 Operating Temperature : -10 ~ +50 [°C]
 Dimension : 148 x 32 x 28 [mm]
 Approvals / Marks : 

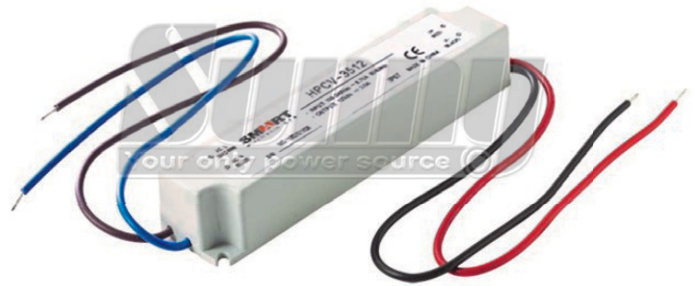

Features:

Constant voltage mode power supply - Suitable for LED lighting and moving sign applications
 Universal AC input / Fully encapsulated with IP67 (for indoor and outdoor use) Full range
 Fully encapsulated with IP67 level
 Protections: Over current / Over Voltage / 100% full load burn-in test

Specification:

	Model	Voltage DC [V]	min. Load [A]	max. Load [A]	Output Tol. [%]	Efficiency [%]	Max. Power [W]	Ripple & Noise [mV] p-p
	HPCV-3512	12	0	3.0	±3	77	35	100
	HPCV-3524	24	0	1.5	±3	77	35	200
INPUT	Voltage	(100 ~ 240)VAC						
	Frequency	(47 ~ 63)Hz						
	Current	0.12A/220VAC 0.25A/100VAC						
	Inrush Current max.	30A/220VAC @ cold start						
	Leakage current	0.25mA/240VAC						
PROTECTION	Over current	Above 150% ~ 200% rated output power or short circuit. Protection type: Hiccup mode, recovers automatically.						
	Over Voltage	Protection type: 110%~150%, shut off, recovers automatically						
	Protection class	Class 2						
	OVER TEMPERATURE	Tj 140°C typically (IC1) Detect on main control IC Protection type: Hiccup mode, recovers automatically after temperature goes down						
	No Load Operation	<1W						
OTHERS	Isolation Resistance	I/P-O/P:>100MΩ / 500VDC / 25~70% RH						
	Set up time	500ms						
	Hold-up Time	50ms/240VAC at full load						
	MTBF Qualification	50K hours @ full load and 25°C						
	AC cable / DC cable	18AWG 250mm Striped & Tinned 18AWG 250mm Striped & Tinned						
	Rise time	250ms						
	LINE REGULATION	±1.0%						
	LOAD REGULATION	±2.0%						
ENVIRONMENT	Temperature	Operating: (-10 ~ +50)°C / Storage: (-40 ~ 80)°C						
	Humidity	Operating: (20 ~ +90)%RH / Storage: (10 ~ 95)%RH Non-condensing						
	VIBRATION	10 ~ 500Hz, 2G 10min./1cycle, period for 60min. each along X,Y, Z axes						
	Temp. Coefficient	±0.03%/°C (0~50°C)						
CERTIFICATION & SAFETY		Safety EN61347-1, EN61347-2-13 Immunity EN61547 Harmonic EN61000-3-2 Magnetic Emission EN55015 RoHS compliant CE mark / compliant UL standard design Pass LPS UL 1310 Class II power unit						
SAFETY & EMC	Withstand voltage	I/P-O/P:3KVAC						
	Safety standards	Design refer to UL1310 Class 2,TUV EN60950-1, EN61347-2-13, CAN/CSA C22.2 No. 223-M91, meet IP67						
	EMS Immunity	Compliance to EN61000-4-2,3,4,5,6,8,11; ENV50204, EN55024, light industry level, criteria A						
	EMI conduction & radiation	Compliance to EN55022 (CISPR22) Class B						
	Harmonic current	EN61000-3-2,-3						
WEIGHT	1pc	HPCV-3512						
		N.W.: 214g G.W.: 227g						
PACKING	Box	0.35 x 0.33 x 0.25 [m]						
		100pcs / 1box						
		G.W.: 24 kg / box						

Mechanical case and cable specification:

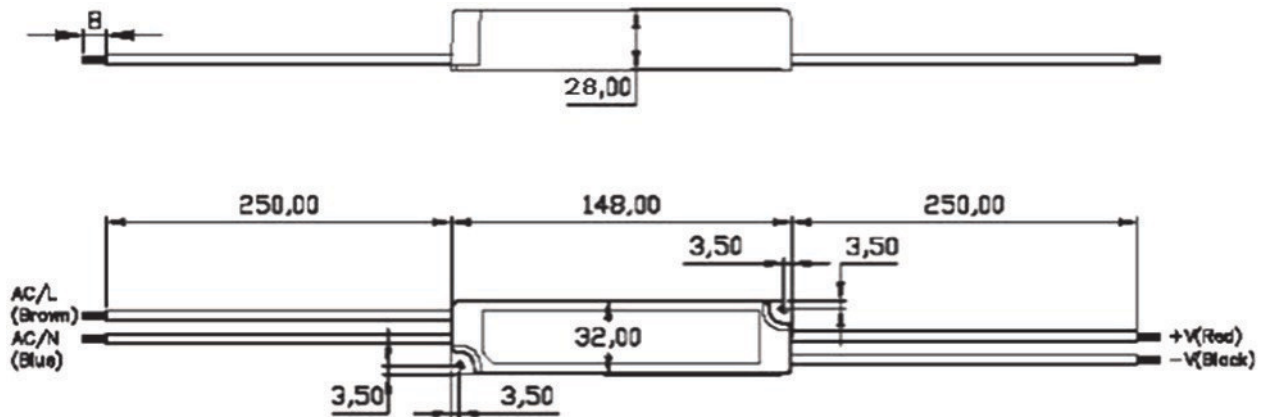

Block diagram:

