

SMD Thick Film Chip Resistors

CONSTRUCTION

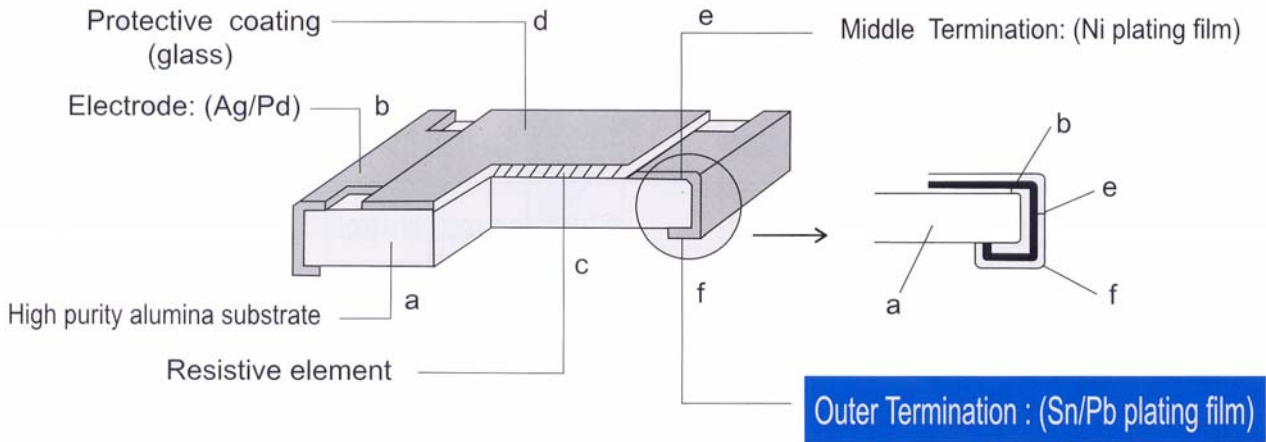

APPLICATION

Telecommunication equipments. Radio and Tape recorders, TV tuners, Video cameras, Watches, Pocket calculators, Automotive Industry (Indicator), Computers, Instruments, Medical and Military equipments.

FEATURES

- ◆ Small size and light weight
- ◆ Reduction of assembly costs and matching with placement machines.
- ◆ Reliability, High quality and Fast delivery.
- ◆ Suitable for both reflow soldering and flow soldering.

DIMENSION

0402/0603/0805/1206/1210/2010/2512

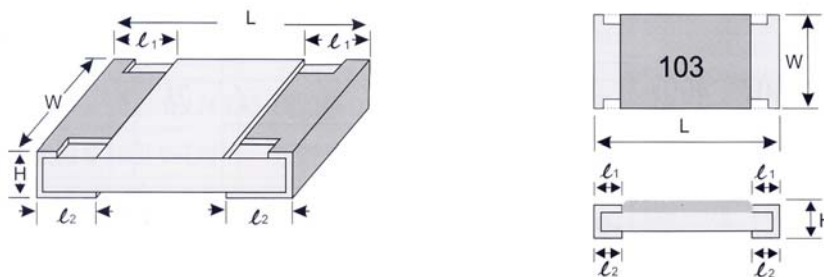

unit : mm

TYPE	L	W	H	l_1	l_2
0402	1.00 ±0.10	0.50 ±0.05	0.30 ±0.05	0.20 ±0.10	0.20 ±0.10
0603	1.60 ±0.20	0.80 ±0.15	0.40 ±0.10	0.30 ±0.20	0.30 ±0.15
0805	2.00 ±0.20	1.25 ±0.15	0.50 ±0.15	0.35 ±0.15	0.35 ±0.15
1206	3.20 ±0.20	1.60 ±0.20	0.55 ±0.15	0.45 ±0.20	0.45 ±0.20
1210	3.20 ±0.20	2.50 ±0.20	0.55 ±0.15	0.50 ±0.20	0.50 ±0.20
2010	5.00 ±0.20	2.50 ±0.20	0.55 ±0.10	0.60 ±0.20	0.60 ±0.20
2512	6.30 ±0.20	3.20 ±0.20	0.55 ±0.10	0.60 ±0.20	0.60 ±0.20

